

**HENN**Ind. e Com. de Móveis Henn  
Mondai - SC - Brasil

☎+55 49 3674.3500

📧@moveishenn  
www.henn.com.br**INSTRUÇÕES DE MONTAGEM****INSTRUCCIONES DE MONTAJE  
ASSEMBLY INSTRUCTIONS****Balcão 03 Gavetas 600mm Connect | Contador 03 Cajones 600mm Connect | Counter 03 Drawers 600mm Connect**

- ☐ C63-35 - Duna/Cristal  
☐ C63-42 - Fendi

Requisitos para montagem  
Requisitor para la montaje  
Assembly Requirements

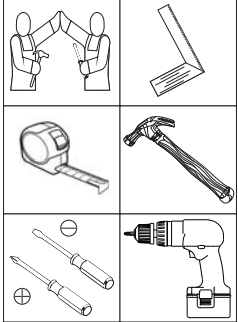

Imagens meramente ilustrativas  
Imágenes meramente ilustrativas  
Images for illustration only

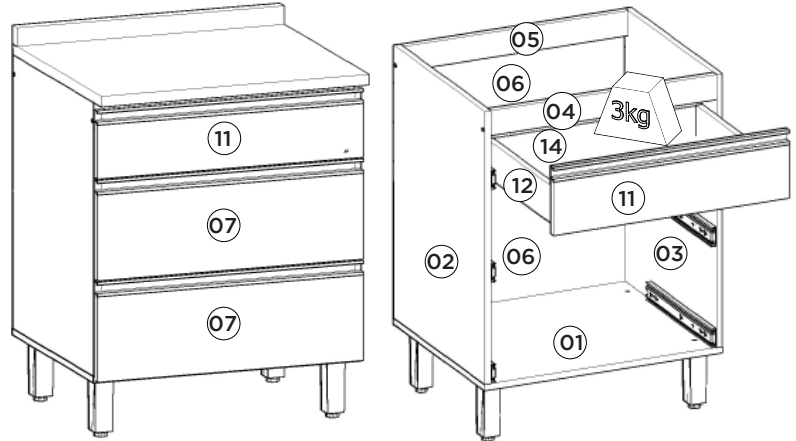

Pesos máximos recomendados com carga distribuída  
Peso máximo recomendado con la carga distribuída  
Recommended maximum weights with evenly distributed.

**Lista de Peças | Lista de piezas | List of parts**

Item	Caixa Caja Box	Qtd Ctd Qty	Descrição   Descripción   Description	Medidas (mm)   Dimensions (mm)   Size (measurements) (mm)
01	1/1	01	Base   Base   Base	600x490x15
02	1/1	01	Lateral esquerda   Lateral izquierda   Left side	660x490x15
03	1/1	01	Lateral direita   Lateral derecha   Right side	660x490x15
04	1/1	01	Travessa frontal   Travesaño frontal   Front crossbar	568x60x15
05	1/1	01	Travessa traseira   Travesaño trasero   Rear bumper	568x60x15
06	1/1	02	Fundo   Fondo   Bottom	592x310x3
07	1/1	02	Frente de gaveta   Frente de cajón   Front of drawer	595x213x15
08	1/1	04	Lado de gaveta   Lado del cajón   Side of drawer	400x122x15
09=13	1/1	02	Fundo de gaveta   Fondo de cajón   Bottom of drawer	524x411x3
10	1/1	02	Ripa de trás   Malla detrás   Rear lath	543x122x15
11	1/1	01	Frente gaveta menor   Frente del cajón menos   Front of drawer smaller	595x136x15
12	1/1	02	Lado de Gaveta menor   Lado del cajón menor   Smallest Drawer Side	400x90x15
13=09	1/1	01	Fundo de gaveta   Fondo de cajón   Bottom of drawer	524x411x3
14	1/1	01	Ripa de trás menor   Listón trasero menos   Rear lath smaller	543x90x15

**AVISO**

Para limpeza de seu móvel, use uma flanela seca ou umedecida, e não utilize produtos químicos que possam danificar seu produto.

**SISTEMA DE MONTAGEM**

O sistema de montagem dos produtos, funciona de acordo com a ordem crescente dos números indicados no desenho. Ex: 01, 02, 03, 04... até a conclusão da montagem.

**ADVERTENCIA**

Para limpieza de su móvil, use una flanela seca o húmeda, y no utilice productos químicos que puedan dañar su producto.

**SISTEMA DE MONTAJE**

El sistema de montaje de los productos funciona de acuerdo con el orden creciente de los números indicados en el dibujo. Ej.: 01, 02, 03, 04... hasta la conclusión del montaje.

**NOTICE**

To clean your furniture, use a dry or wet cloth, and do not use chemicals that may damage your product.

**ASSEMBLY SYSTEM**

The products' assembly system works according to the increasing order of the indicated numbers. For example: 01, 02, 03, 04 ... to the end of the assembly.

**Ferragens | Herrajes | Hardware**

<b>A</b> 04x  Parafuso 7,0x40mm CHT. Tornillo 7,0x40mm CHT. Screw 7,0x40mm CHT.	<b>B</b> 01x  Parafuso 5,0x50mm FLA. Tornillo 5,0x50mm FLA. Screw 5,0x50mm FLA.	<b>C</b> 02x  Parafuso 4,5x50mm CHT. Tornillo 4,5x50mm CHT. Screw 4,5x50mm CHT.	<b>D</b> 04x  Parafuso União 30mm Tornillo Unión 30mm Union Screw 30mm	<b>E</b> 08x  Parafuso 3,5x40mm CHT. Tornillo 3,5x40mm CHT. Screw 3,5x40mm CHT.	<b>F</b> 08x  Adesivo tapa parafuso 10mm Adhesivo tapón de tornillo 10mm Bolt cover adhesive 10mm	<b>G</b> 10x  Parafuso 3,5x14mm FLA. Tornillo 3,5x14mm FLA. Screw 3,5x14mm FLA.	<b>H</b> 62x  Parafuso 3,5x12mm CHT. Tornillo 3,5x12mm CHT. Screw 3,5x12mm CHT.
<b>I</b> 06x  Parafuso 3,0x16mm CHT. Tornillo 3,0x16mm CHT. Screw 3,0x16mm CHT.	<b>J</b> 06x  Parafuso 3,0x30mm CHT. Tornillo 3,0x30mm CHT. Screw 3,0x30mm CHT.	<b>K</b> 32x  Cavilha 8x25mm Cinta 8x25mm Dowel 8x25mm	<b>L</b> 01x  Divisor talheres 511x398mm Divisor cubiertos 511x398mm Cutlery divider 511x398mm	<b>M</b> 17x  Prego 10x10mm Clavo 10x10mm Nail 10x10mm	<b>N</b> 10x  Cantoneira plástica Cantoneira plástica Plastic angle brackets	<b>O</b> 04x  Pé 145mm x 42mm Pie 145mm x 42mm Foot 145mm x 42mm	<b>P</b> 06x  Cantoneira suporte triangular Cantoneira soporte triangular Triangle support angle
<b>Q</b> 03x  Puxador MOV 595mm Tirador MOV 595mm MOV 595mm Handle	<b>R</b> 03x  Corrediza telescópica Diapositivas telescópicas Telescopic slides	<b>S</b> 01x  Perfil "H" 580mm Perfil "H" 580mm Profile "H" 580mm	<b>T</b> 02x  Sachê de cola Bolsa de pegamento Glue bag	<b>U</b> 01x  Suporte de fixação Soporte de fijación Mounting bracket	<b>V</b> 01x  Proteção para cantoneira Ángulo de protección Protection angle	<b>W</b> 01x  Buchta plástica 8mm Buchta de plástico 8mm 8mm plastic bushing	<b>X</b> 06x  Batente PVC para Porta Parada de PVC para Puerta PVC Door Stop



O parafuso (D) deve ser usada somente quando este módulo for acoplado a outro módulo componível Henn.



El tornillo (D) se debe utilizar sólo cuando el módulo está conectado a otro módulo componible Henn.



The screw (D) should be used only when this module is attached to another Henn modular module.

**RECOMENDAÇÃO**

Para fixar o móvel na parede usar o suporte de fixação (U), o parafuso 3,5x14mm FLA (G), a Bucha 8mm (W) e o parafuso 5,0x50mm FLA (B).

**RECOMENDACIÓN**

Para conectar el móvil a la pared con el soporte (U), tornillo 3,5 x14mm FLA (G), el casquillo de 8 mm (W) y el 5,0 x50mm tornillo FLA (B).

**RECOMMENDATION**

To fix the furniture to the wall use the mounting bracket (U), the 3.5x14mm FLA (G) screw, the 8mm bushing (W) and the 5.0x50mm FLA screw (B).

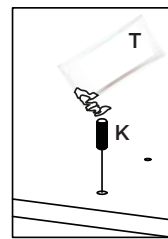
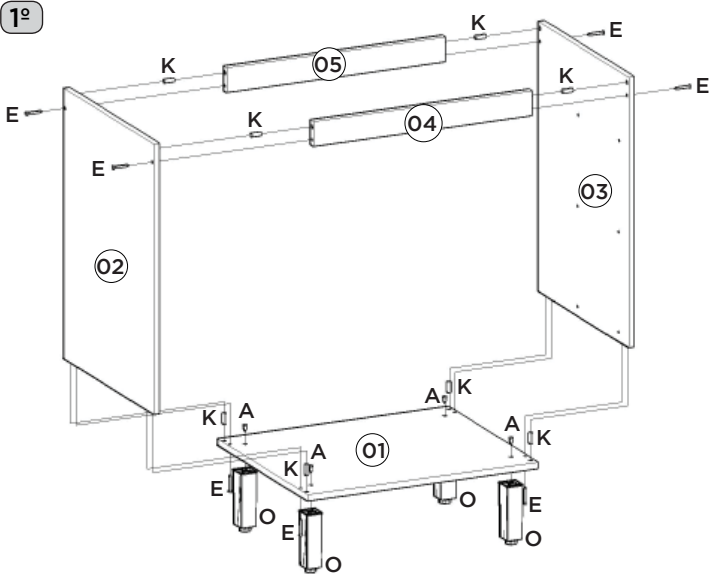

Utilizar o sachê de cola (T) em todas as cavilhas (K) do produto.

Con el pegamento sobre (T) en todos los pernos (K) producto.

Use the glue sachet (T) on all the pegs (K) of the product.

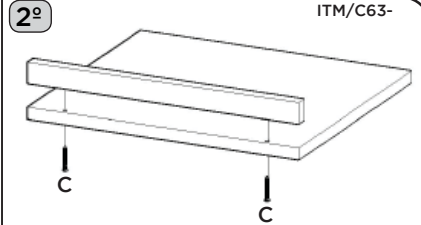

Esse tampo é opcional e é vendido separadamente (C903-33).

Esta vez es opcional y se vende por separado (C903-33).

This top is optional and is sold separately (C903-33).

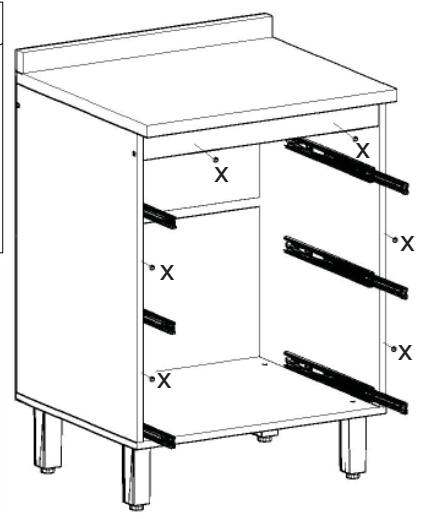
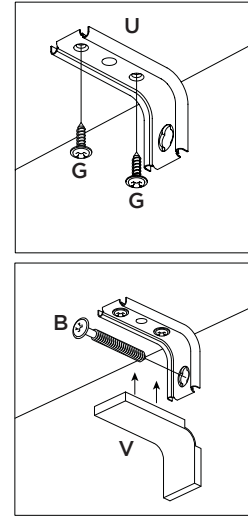
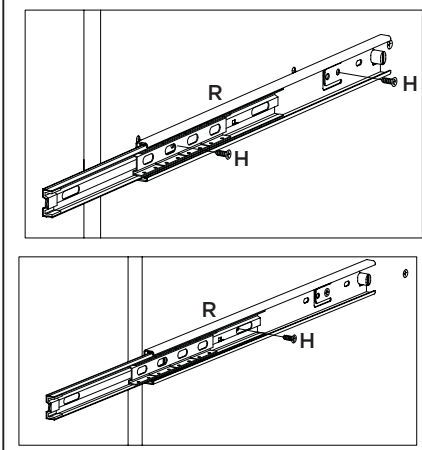
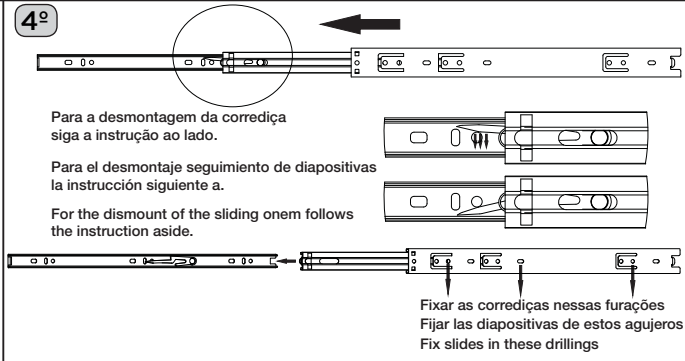
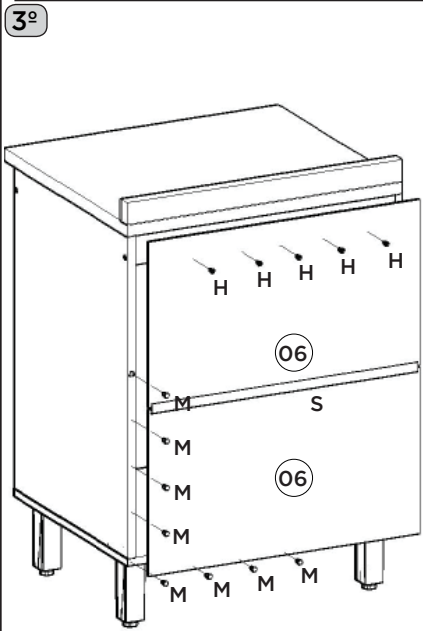
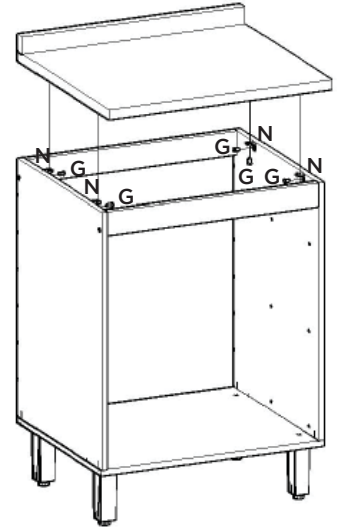

5º Montagem Gavetas / Montaje Gavetas / Drawers assembly

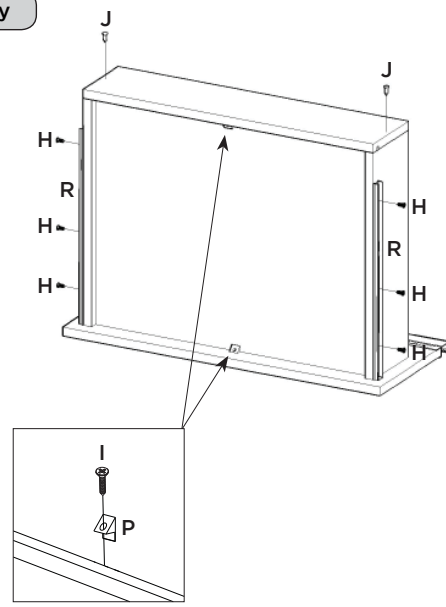
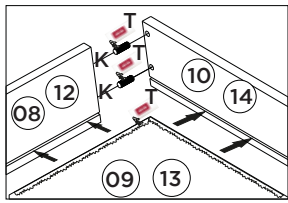
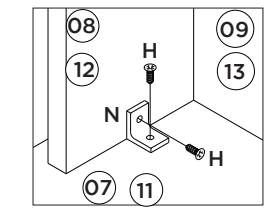
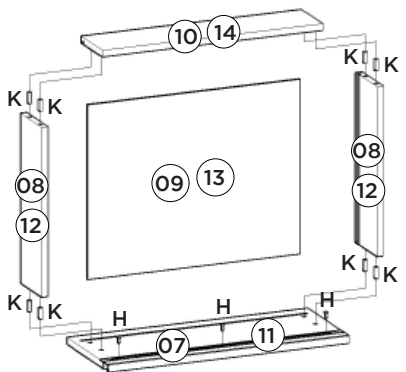

A corredeira (R) deverá ser alinhada com a parte de baixo do lado de gaveta (08 e 12).

La corredera (R) debe estar alineada con la parte de por el lado del cajón (08 y 12).

The slide (R) should be aligned with the bottom of the drawer side (08 and 12).